

ULTRA LOW DISTORTION LOW PROFILE LINE MATCHING TRANSFORMER

P3156

Features

- * Ultra Low Distortion
- * Lead-free (Pb-free)
- * RoHS compliant
- * Low Profile (11mm)
- * Extended Frequency Response
- * IEC 60950 and UL 60950 certified
- * UL Recognized Component
- * Flat TX and RX Responses
- * High Thermal Stability

Applications

- * V.90 and V.92 modems
- * Line matching

DESCRIPTION

P3156 is intended for data communications to V.90 and V.92 (56kbps) data rates. P3156 is specifically designed to be matched to both 600 ohm and complex impedance telephone lines, using a minimum of external components, with very flat TX and RX frequency responses.

P3156 has extended flat frequency response from 30Hz to 4kHz with very low levels of signal distortion at signal frequencies as low as 150Hz.

P3156 also exhibits stable characteristics over its operating temperature range to maximize data throughput under varying environmental conditions without the need for modem retraining.

P3156 is certified to IEC 60950 and UL 60950. P3156 is a UL Recognized Component and is supported by an IEC CB Test Certificate. The part is completely lead-free, compliant with RoHS Directive 2002/95/EC, and suitable for lead-free and conventional processing.

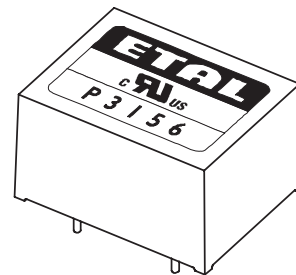
**RoHS**
COMPLIANT

SPECIFICATIONS

Electrical

At T = 25°C and as circuit Fig. 2 unless otherwise stated.

Parameter	Conditions	Min	Typ	Max	Units	
Insertion Loss	f = 2kHz, R _L = 510Ω	-	4.8	-	dB	
Frequency Response	LF -3dB cutoff	-	10	-	Hz	
	HF -3dB cutoff	-	8	-	kHz	
	100Hz - 4kHz	-	-	±0.2	dB	
Return Loss	200Hz - 4kHz	14	-	-	dB	
Distortion ⁽¹⁾	0dBm in line, 3rd Harmonic	-	-	-90	dBm	
	f = 600Hz	-	-	-	dBm	
	-3dBm in line, 3rd Harmonic	-	-77	-	dBm	
Balance	DC - 5kHz	80	-	-	dB	
Saturation	Excitation 50Hz	-	-	10	Vrms	
	250Vrms. Output voltage across line	-	-	65	Vpeak	
Voltage isolation ⁽²⁾	50Hz	3.88	-	-	kVrms	
	DC	5.5	-	-	kV	
Operating range:	Ambient temperature	Functional	-25	-	+85	°C
		Storage	-40	-	+125	°C
		Humidity	-	-	95	%R.H.

Lumped equivalent circuit parameters as Fig. 1

DC resistance, R _{DC} ⁽³⁾	Sum of windings	-	280	-	Ω
Leakage inductance ΔL		-	20	-	mH
Shunt inductance L _p ⁽⁴⁾	10mV 200Hz	-	14	-	H
Shunt loss R _p ⁽⁴⁾	10mV 200Hz	12	-	-	kΩ

Notes

1. Third harmonic typically exceeds other harmonics by 10dB.
2. Components are 100% tested at 6.5kV DC.
3. Caution: do not pass DC through windings. Telephone line current, etc. must be diverted using semiconductor line hold circuit.
4. At signal levels greater than 100mV, L_p will increase and R_p will decrease slightly but the effect is usually favourable to the return loss characteristic.

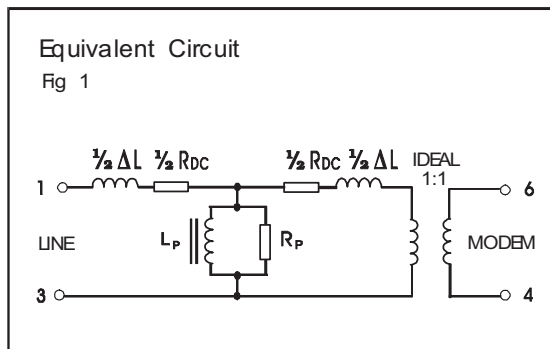

MATCHING RECOMMENDATIONS

600Ω MATCH

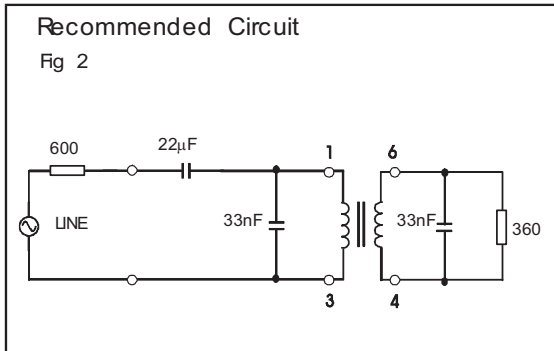

In practice the 360Ω load resistor in figure 2 will connect to a low output impedance TX driver. The 33nF capacitor on the load side should appear in parallel with the 360Ω resistor (rather than in parallel with the transformer winding) to obtain flat TX response to line.

Figure 3 gives flat RX and TX responses against the complex reference impedance (typically ±0.5dB 30Hz - 4kHz) with return loss better than 15dB.

EUROPEAN CTR21 COMPLEX MATCH

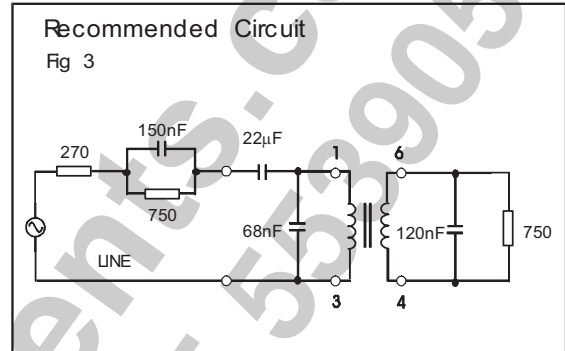

In practice, the 750Ω load resistor will connect to a low output impedance TX driver. The 120nF capacitor, which should have a temperature stable dielectric, should appear in parallel with the 750Ω resistor (rather than in parallel with the transformer winding) to obtain flat TX response to line.

For recommended matching to other reference impedances please contact Profec Technologies.

CONSTRUCTION

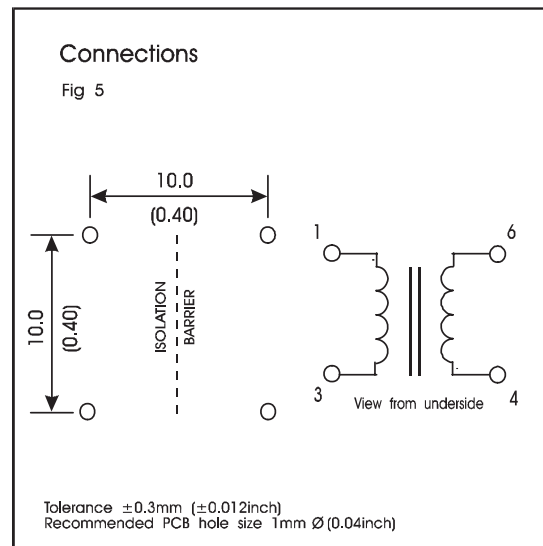
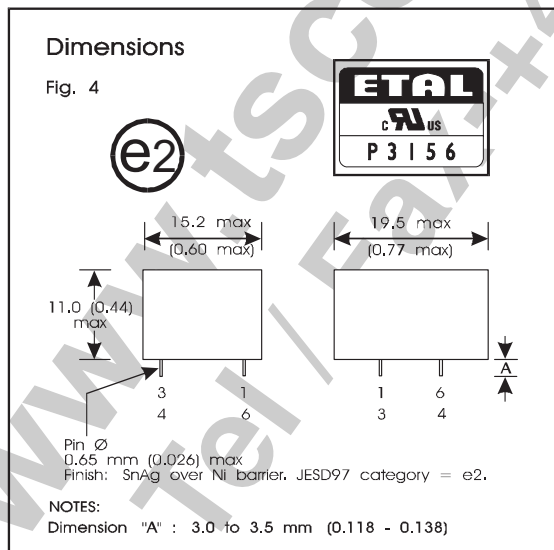

Dimensions shown are in millimetres (inches).
Geometric centres of outline and pin grid coincide within a tolerance circle of 0.6mmØ.
Windings may be used interchangeably as primary or secondary.

SAFETY

Constructed in accordance with IEC 60950-1:2001, EN60950-1:2001 and UL 60950-1 First Edition, supplementary insulation, 250Vrms maximum working voltage, flammability class V-0. Distances through solid insulation 0.4mm minimum.

CERTIFICATION

Certified under the IEC CB scheme (Certificate DK-9431) to IEC 60950-1:2001, sub-clauses 1.5, 1.5.1, 1.5.2, 1.7, 1.7.1, 2, 2.9, 2.9.1, 2.9.2, 2.9.3, 2.10, 2.10.1, 2.10.2, 2.10.3, 2.10.3.1, 2.10.3.3, 2.10.4, 2.10.5, 2.10.5.1, 2.10.5.4, 4, 4.7, 4.7.1, 4.7.3, 4.7.3.1, 4.7.3.4, 5, 5.2, 5.2.1, and 5.2.2 for a maximum working voltage of 250Vrms, nominal mains supply voltage not exceeding 300Vrms and a maximum operating temperature of 85°C in Pollution Degree 2 environments, supplementary insulation, including national differences for Denmark, Finland, Germany, Norway, Sweden, Switzerland, USA, Canada and UK. Recognized under the Component Recognition Program of Underwriters Laboratories Inc. to US and Canadian requirements CAN/CSA C22.2 No. 60950-1-03/UL60950-1, First Edition, based on IEC 60950-1, First Edition, maximum working voltage 250Vrms, Pollution Degree 2, reinforced insulation.

UL File number E203175.

Additionally, Profec Technologies certifies all transformers as providing voltage isolation of 3.88kVrms, 5.5kV DC minimum. All shipments are supported by a Certificate of Conformity to current applicable safety standards.

ABSOLUTE MAXIMUM RATINGS

(Ratings of components independent of circuit).

Short term isolation voltage (2s)	4.6kVrms, 6.5kVDC
DC current	100µA
Storage temperature	-40°C to +125°C
Lead temperature, 10s	260°C

COPYRIGHT

ETAL and P3156 are Trade Marks of Profec Technologies Ltd. The Trade Mark ETAL is registered at the UK Trade Marks Registry.

Profec Technologies Ltd. is the owner of the design right under the Copyright Designs and Patents Act 1988 and no rights or licences are hereby granted or implied to any third party.

© 1997-2006 Profec Technologies Ltd.
Reproduction prohibited.



ISO 9001
FM 25326

ETAL Group Oy, Kuormatie 14, FIN-03101, Nummela
Telephone: +358 (0)20 7500 330 Fax: +358 (0)20 7500 333
Website: www.etalgroup.com Email: etalgroup@egruppen.com